



ANDAMIOS A CREMALLERA
MAST CLIMBING PLATFORMS



CAMAC 1500

- Andamio idóneo para rehabilitación.
- Gran facilidad en el montaje y uso gracias a la gran ligereza de sus columnas.
- Con nuevo sistema de autonivelación.
- Máxima seguridad y robustez.
- Acabados galvanizados.
- Suelo metálico incorporado en plataformas y extensibles.
- Columna triangular compatible con: EC-HA 500/120, EC-600/120 y ECP-500/120.
- Mast climbing platform suitable for refurbishment work.
- Easy to install and use. Great loading capacity.
- With a new automatic self-levelling system.
- Maximum safety and robustness.
- Galvanized platforms and columns.
- Metallic floor incorporated in platforms and extendibles.
- Triangular mast compatible with: EC-HA 500/120, EC-600/120 and ECP-500/120.

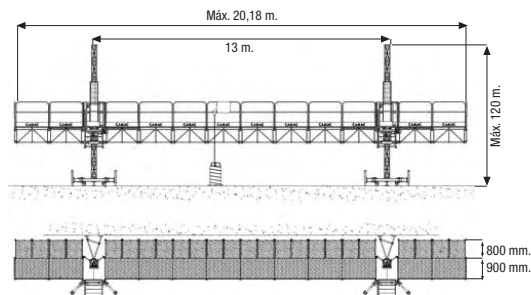
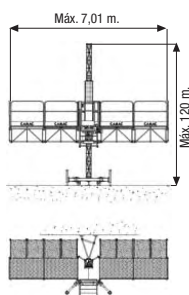
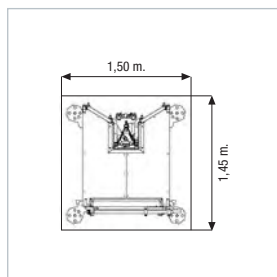
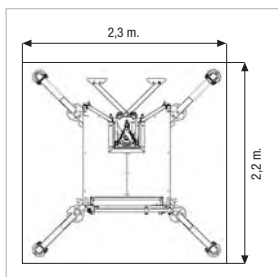

CARACTERÍSTICAS	SPECIFICATIONS		MONOCOLUMNA SINGLE MAST	BICOLUMNA DOUBLE MAST	MONOCOLUMNA SINGLE MAST	BICOLUMNA DOUBLE MAST
Altura máxima	Maximun height	m.	120	120		
Distancia entre anclajes	Distance between ties	m.	6	6	750 Kg.	1.500 Kg.
Largo plataforma máximo	Max. platform length	m.	7,01	20,18		
Ancho plataforma	Platform width	m.	0,9 + 0,8	0,9 + 0,8		
Velocidad subida	Climbing speed	m/min.	7	7	2,5 Kw.	2,2 Kw.
Capacidad carga máxima	Max. loading capacity	Kg.	750	1.500		
Potencia motor trifásico	Three-phase motor power	Kw.	2,5	2,5 (2 motores/2 motors)	220 V.	380 V.
Potencia motor monofásico	Single-phase motor power	Kw.	2,2	2,2 (2 motores/2 motors)	220 V.	380 V.





CAMAC 2000

KIT ESQUINERO / CORNER KIT



EXTENSIONES TELESCÓPICAS
EXTENSIONES TELESCÓPICAS

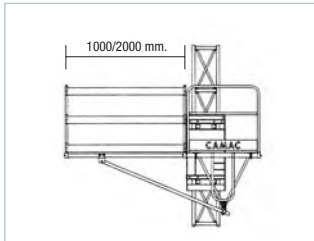

- Siempre pensando en la comodidad del usuario, hemos implementado importantes mejoras técnicas de serie, como los gatos de nivelación y el nuevo sistema de autonivelación que se suministra en cada grupo motriz.
- Columna triangular compatible con: EC-1000/150, ECP-1000/150 y EPM-1000/150.
- Always bearing in mind the users' comfort, we have included some important technical improvements such as the level jacks and the new automatic self-levelling system, supplied with the driving group.
- Triangular mast compatible with: EC-1000/150, ECP-1000/150 and EPM-1000/150.

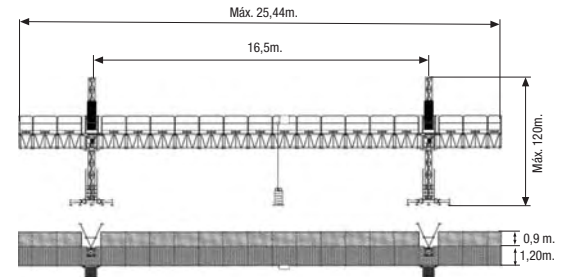
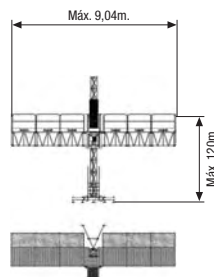
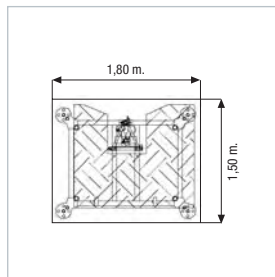
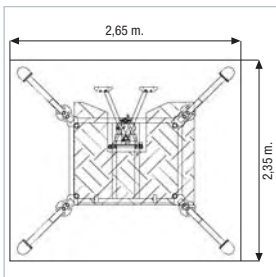

CARACTERÍSTICAS	SPECIFICATIONS		MONOCOLUMNA SINGLE MAST	BICOLUMNA DOUBLE MAST	MONOCOLUMNA SINGLE MAST	BICOLUMNA DOUBLE MAST
Altura máxima	Maximum height	m.	120	120		
Distancia entre anclajes	Distance between ties	m.	6	6	1.160 Kg.	2.320 Kg.
Largo plataforma máximo	Max. platform length	m.	9,04	25,44		
Ancho plataforma	Platform width	m.	1,2 + 0,9	1,2 + 0,9		
Velocidad subida	Climbing speed	m/min.	10	10	4,1 Kw.	4,1 Kw.
Capacidad carga máxima	Max. loading capacity	Kg.	1.160	2.320		
Potencia del motor	Motor power	Kw.	4,1	4,1 (2 motores/2 motors)	380 V.	380 V.



ANDAMIOS A CREMALLERA
MAST CLIMBING PLATFORMS

CAMAC 3000

KIT ESQUINERO / CORNER KIT



EXTENSIONES TELESCÓPICAS
EXTENSIONES TELESCÓPICAS

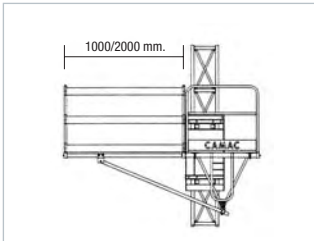

- La combinación de su máxima seguridad y facilidad en el montaje y uso, junto con su rápida velocidad de 10 m/min., permiten un gran ahorro de tiempo en obra.
- Gran robustez.
- Acabados galvanizados.
- Columna cuadrada compatible con: EC-1700/150, ECP-1500/150 y EPM-1500/150.
- The combination of maximum safety with easy installation and use, along with its fast speed of 10 m/min., become an important saving of time at works.
- Great robustness.
- Galvanized platforms and masts.
- Square mast compatible with: EC-1700/150, ECP-1500/150 and EPM-1500/150.

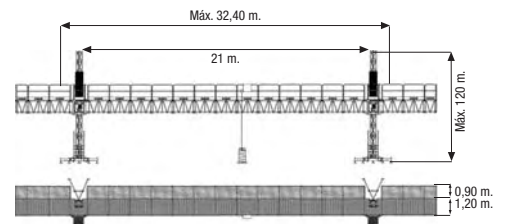
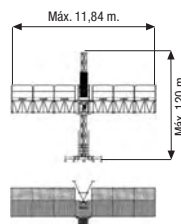
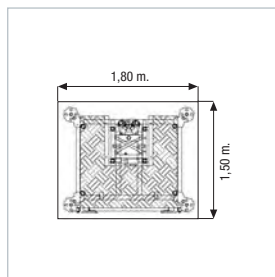
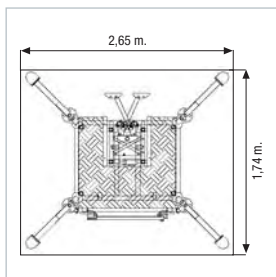

CARACTERÍSTICAS	SPECIFICATIONS		MONOCOLUMNA SINGLE MAST	BICOLUMNA DOUBLE MAST	MONOCOLUMNA SINGLE MAST	BICOLUMNA DOUBLE MAST
Altura máxima	Maximun height	m.	120	120		
Distancia entre anclajes	Distance between ties	m.	9	9	1.710 Kg.	3.420 Kg.
Largo plataforma máximo	Max. platform length	m.	11,84	32,40		
Ancho plataforma	Platform width	m.	1,2 + 0,9	1,2 + 0,9		
Velocidad subida	Climbing speed	m/min.	10	10	4,1 Kw.	4,1 Kw.
Capacidad carga máxima	Max. loading capacity	Kg.	1.710	3.420		
Potencia del motor	Motor power	Kw.	4,1	4,1 (2 motores/2 motors)	380 V.	380 V.



CAMAC 3000 AUTOESTABLE / CAMAC 3000 SELFSTANDING

- Ideal para trabajos de poca altura donde sea necesario ir cambiando la posición del andamio.
- Su gran capacidad permite su uso en cualquier tipo de trabajos como obra nueva, rehabilitación, pintura, etc.
- Columna cuadrada compatible con: EC-1700/150, ECP-1500/150 y EPM-1500/150.
- Ideal for works of little height where there is a need for changing the location of the scaffold.
- Its big capacity allows its use in any type of work such new buildings, refurbishments, painting, etc.
- Square mast compatible with: EC-1700/150, ECP-1500/150 and EPM-1500/150.

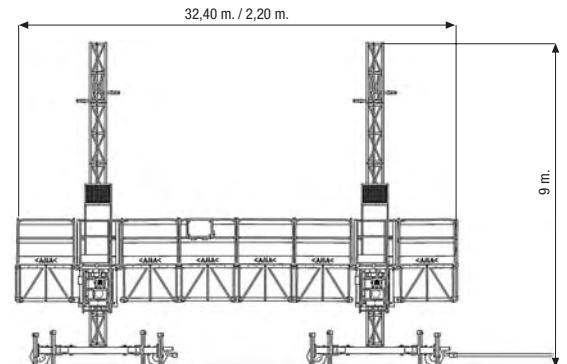
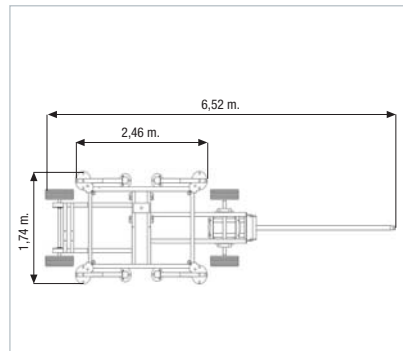
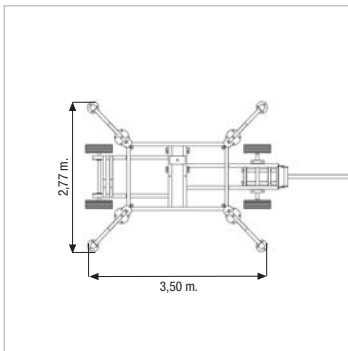

CARACTERÍSTICAS	SPECIFICATIONS	m.	CON ANCLAJES CADA 9 m. WITH TIES EACH 9 m.		CON 1 ANCLAJE A 9 m. WITH 1 TIE TO 9 m.		SIN ANCLAJES WITHOUT TIES	
			MONOCOLUMNA SINGLE MAST	BICOLUMNA DOUBLE MAST	MONOCOLUMNA SINGLE MAST	BICOLUMNA DOUBLE MAST	MONOCOLUMNA SINGLE MAST	BICOLUMNA DOUBLE MAST
Altura máxima	Maximun height	m.	120	120	17,54	17,54	8,54	8,54
Largo plataforma máximo	Max. platform length	m.	11,84	32,40	10,20	20,20	10,20	20,20
Ancho plataforma	Platform width	m.	1,2 + 0,9	1,2 + 0,9	1,2 + 0,9	1,2 + 0,9	1,2 + 0,9	1,2 + 0,9
Velocidad subida	Climbing speed	m/min.	10	10	10	10	10	10
Velocidad traslación	Translation speed	m/min.	—	—	—	—	3	3
Capacidad carga máxima	Max. loading capacity	Kg.	1.710	3.420	1.710	3.420	1.710	3.420
Potencia del motor	Motor power	Kw.	4,1	4,1 (2 motores/motors)	4,1	4,1 (2 motores/motors)	4,1	4,1 (2 motores/motors)
Potencia del motor traslación	Translation motor power	Kw.	—	—	—	—	1,5	1,5
			1.710 Kg.	3.420 Kg.	1.710 Kg.	3.420 Kg.	1.710 Kg.	3.420 Kg.
			4,1 Kw.	4,1 Kw.	4,1 Kw.	4,1 Kw.	4,1 Kw.	1,5 Kw.