

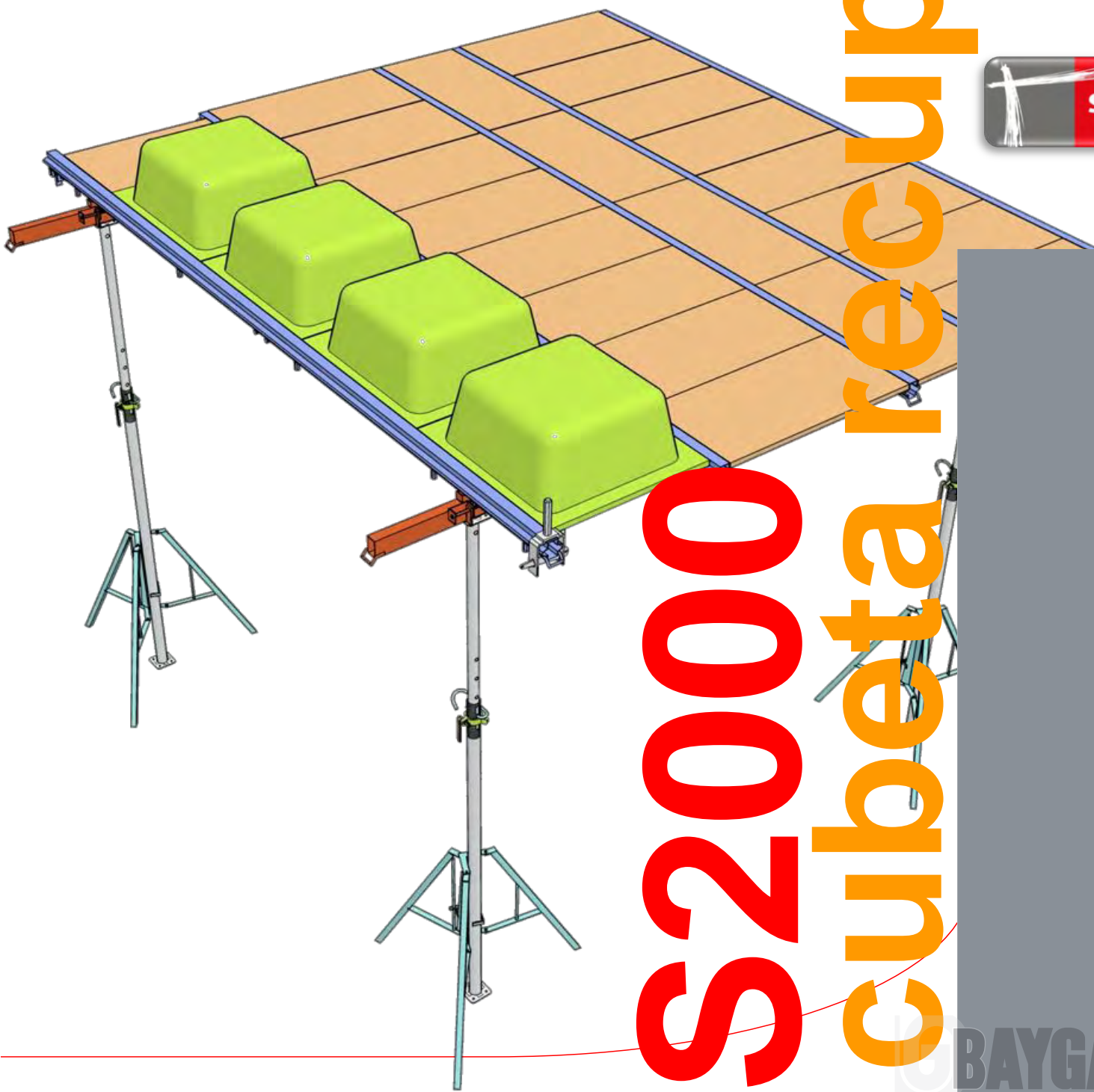

\$20000 cubbeta recuperabile



Portatasopandas

Portata-sopanda

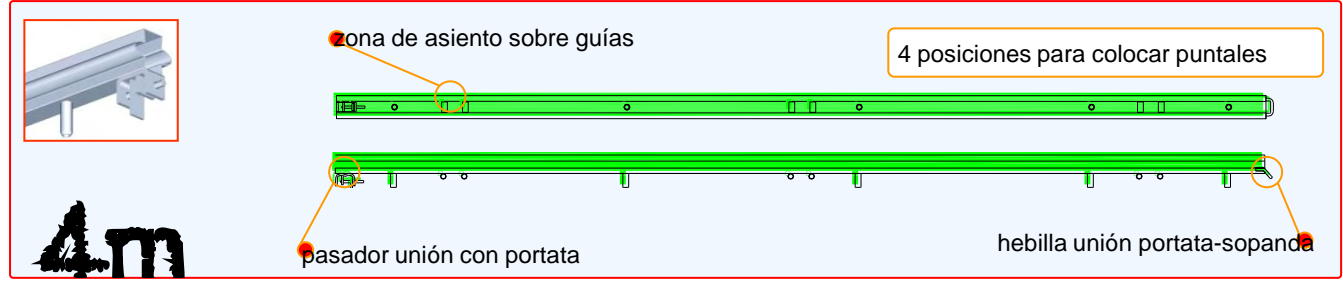

Denominación	Portatasopanda 4m	Portatasopanda 3m	Portatasopanda 2m
L (mm)	4.000	3.000	2.000
* Peso Kg.	27,0	20,0	13,5
Secc. Tubo	80 x 50 x 2	80 x 50 x 2	80 x 50 x 2
Area sección (cm ²)	6,51	6,51	6,51
Ix (cm ⁴)	53,1	53,1	53,1
Wx (cm ³)	13,28	13,28	13,28

* Para Material Galvanizado y espesor 2,5mm

* Acero tipo: S275JR, EN 10025-2:2004

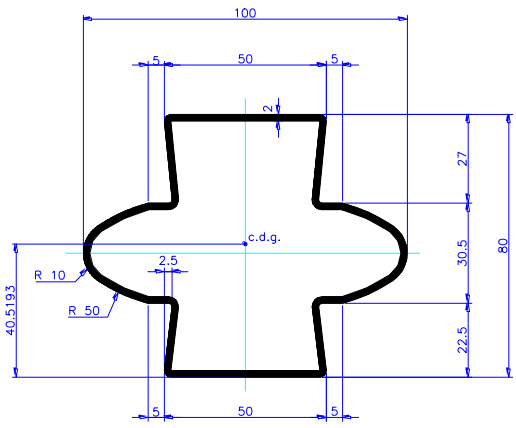

A = 6.506967
 Ix = 53.1036
 Iy = 47.0050
 X = 10
 Y = 8
 Wx = 13.2759
 Wy = 9.4010
 c.d.g. = 40.5193

en cms

Guías

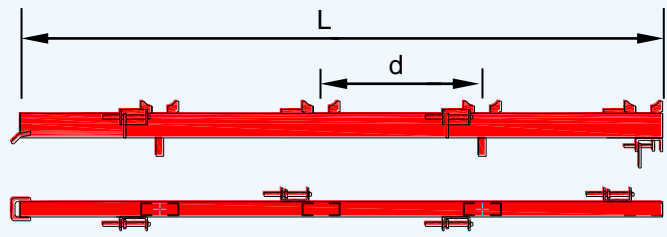
 Dimensiones guías largas
 S2000 de cubetas:

Denominación	Guía n12 4,80	Guía n16 5,00	Guía n17 4,25	Guía n21 4,45
L (mm)	4,786	5,024	4,251	4,447
D (cm)	80	84	85	89
Kg	25,4	26,5	22,5	23,6

Denominación	Guía n12 2,40	Guía n16 2,51	Guía n17 2,55	Guía n21 2,67
L (mm)	2,392	2,510	2,550	2,667
D (cm)	80	84	85	89
Kg	12,8	13,4	13,6	14,3

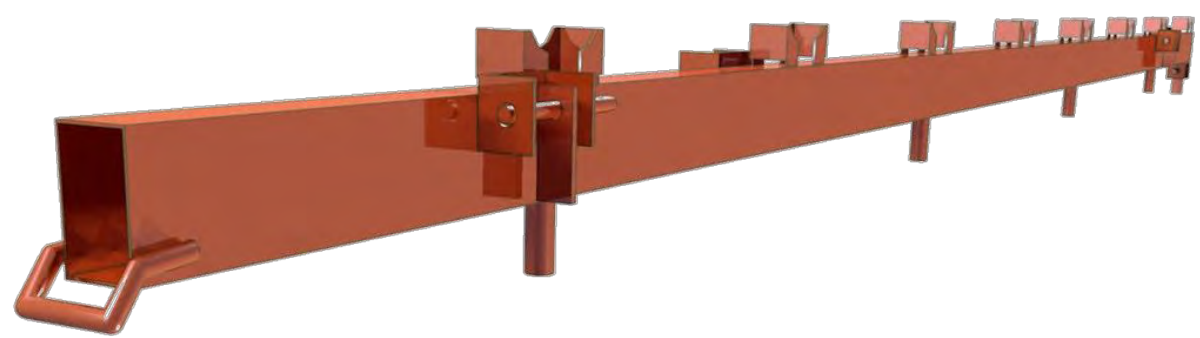

* Para Material Galvanizado

* Acero tipo: E275-CR1 UNE-EN 10305-5

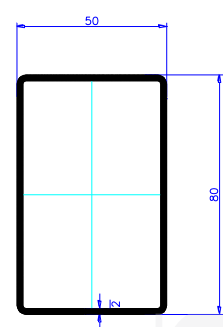

A = 4.971327
 Ix = 43.9864
 Iy = 21.2741
 X = 5
 Y = 8
 Wx = 10.9966
 Wy = 8.5096

Cubetas



Denominación Cubeta		Cubeta canto 20	Cubeta canto 25	Cubeta canto 30	Cubeta canto 35	Cubeta canto 40
Nervio 12 -17	Dimensiones mm		745x799	745x799	745x799	745x799
	Vol. m3/ud.desalojados		0,098	0,113	0,125	0,134
	Peso Kg		8,06	8,56	9,5	9,7
Nervio 16 -21	Dimensiones mm		785x838	785x838	785x838	785x838
	Vol. m3/ud.desalojados		0,098	0,113	0,125	0,134
	Peso Kg		8,78	9,42	10,4	10,6

Denominación Media Cubeta		½ Cubeta canto 20	½ Cubeta canto 25	½ Cubeta canto 30	½ Cubeta canto 35	½ Cubeta canto 40
Nervio 12	Dimensiones mm		745x398	745x398	745x482	745x482
	Vol. m3/ud.desalojados		0,040	0,045	0,066	0,071
	Peso Kg		4,4	4,6	5,2	5,5
Nervio 16	Dimensiones mm		785x435	785x435	785x524	785x524
	Vol. m3/ud.desalojados		0,043	0,049	0,072	0,077
	Peso Kg		4,8	5,0	5,8	6,1
Nervio 17	Dimensiones mm		799x392	799x392	799x428	799x428
	Vol. m3/ud.desalojados		0,046	0,054	0,066	0,071
	Peso Kg		4,6	4,8	5,1	5,4
Nervio 21	Dimensiones mm		838x434	838x434	838x550	838x550
	Vol. m3/ud.desalojados		0,047	0,054	0,08	0,086
	Peso Kg		5,2	5,5	6,3	6,6

Polipropileno especial .
 Densidad=0.898 g/cm3.
 Índice de fluidez 1.9 g/10min a 230°C y 2,16N

Denom.	C (cm)	EE (cm)	A (mm)	L (mm)	omega (mm)	tablero 27mm (mm)
Nervio 12	25,30,35,40	80	745	799	NO LLEVA	745x500
Nervio 16	25,30,35,40	84	785	838	NO LLEVA	785x500
Nervio 17	25,30,35,40	85	799	745	799x100	799x500
Nervio 21	25,30,35,40	89	838	785	838x100	838x500

Casetón recuperable + Sistema 2000

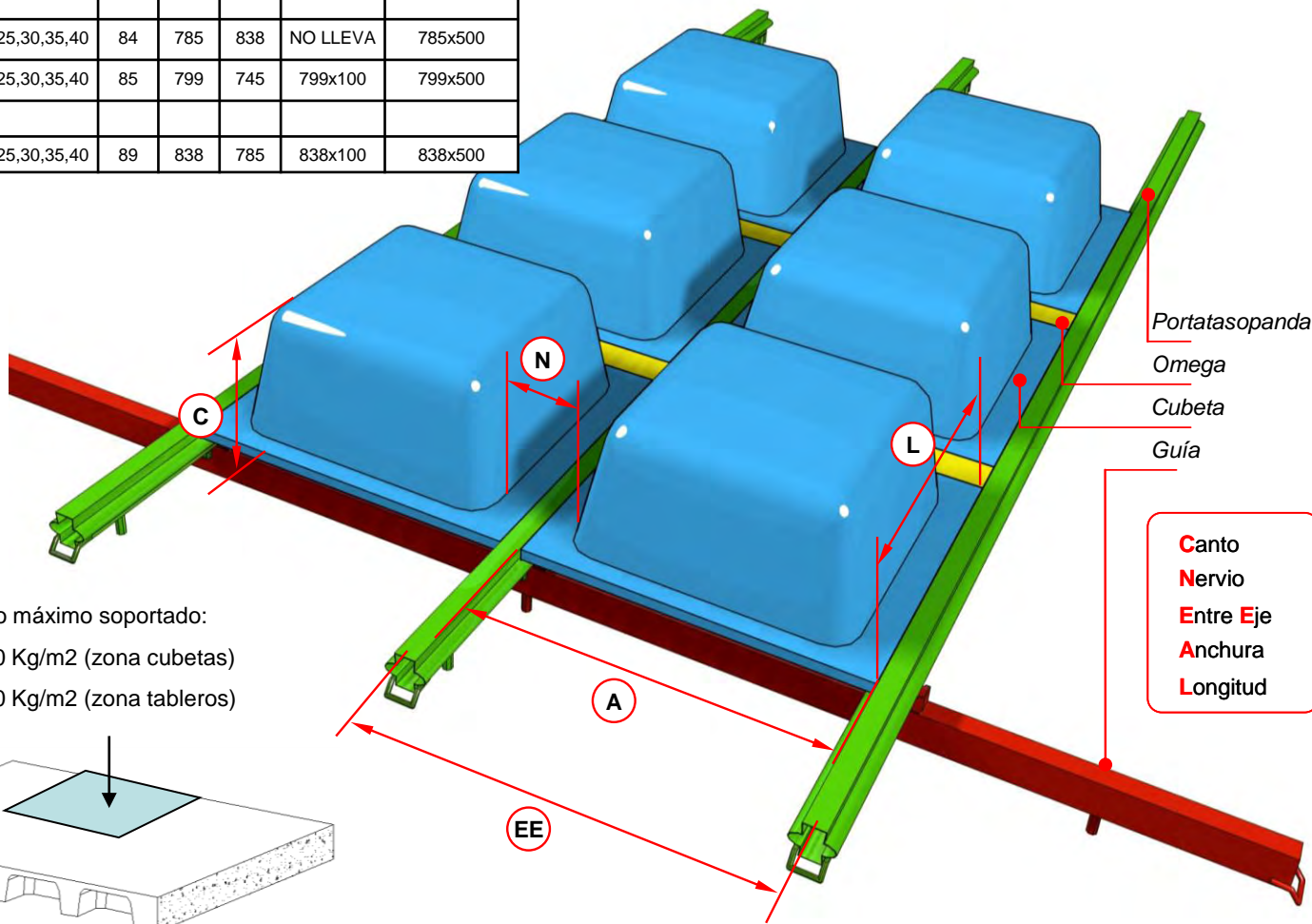

Geometrías Cubetas nervios 12 y 17

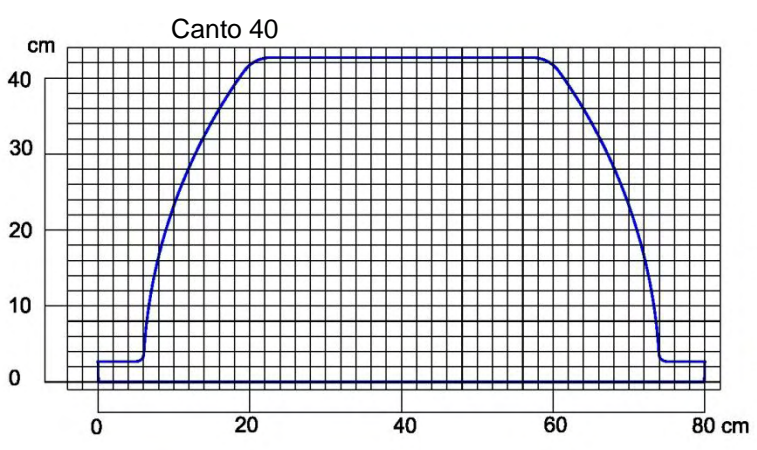
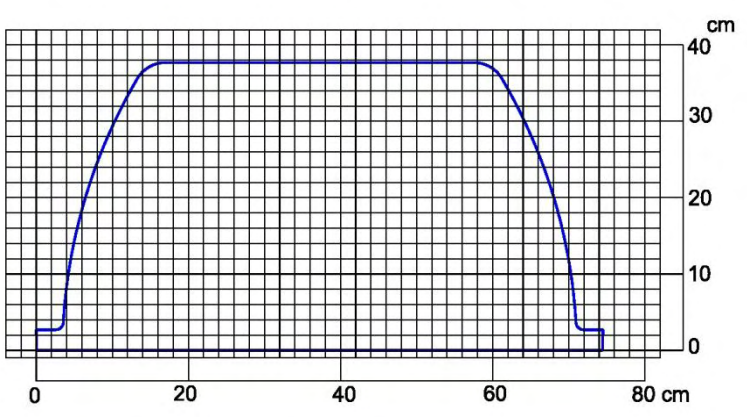
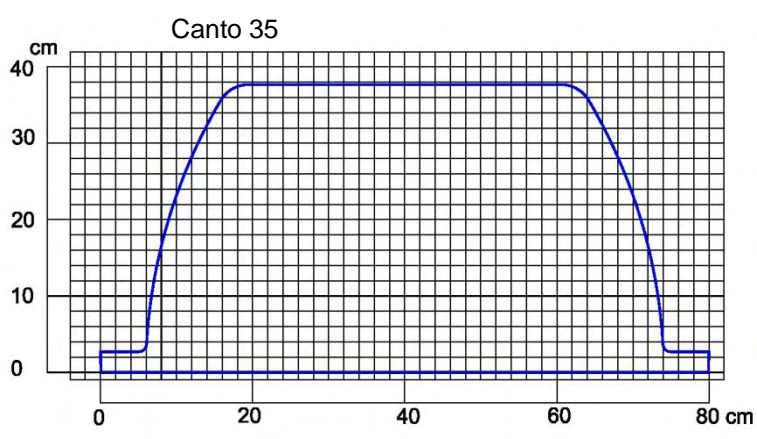
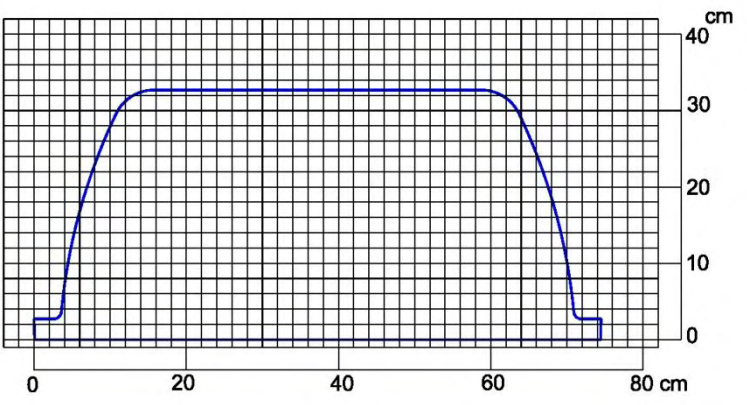
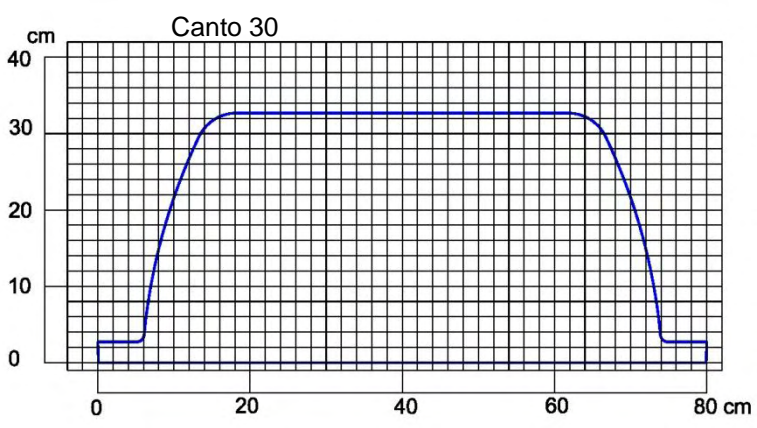
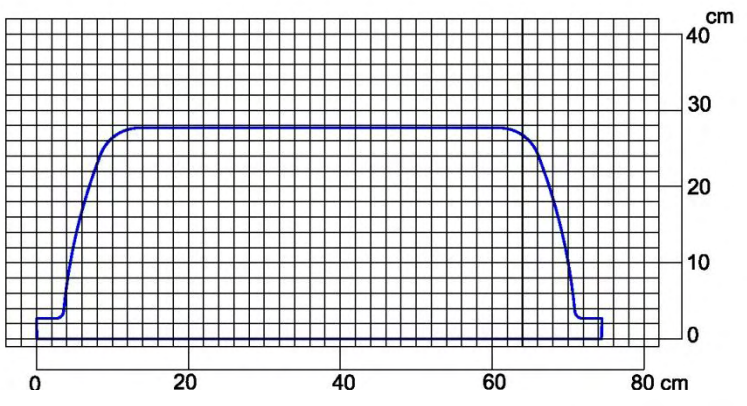
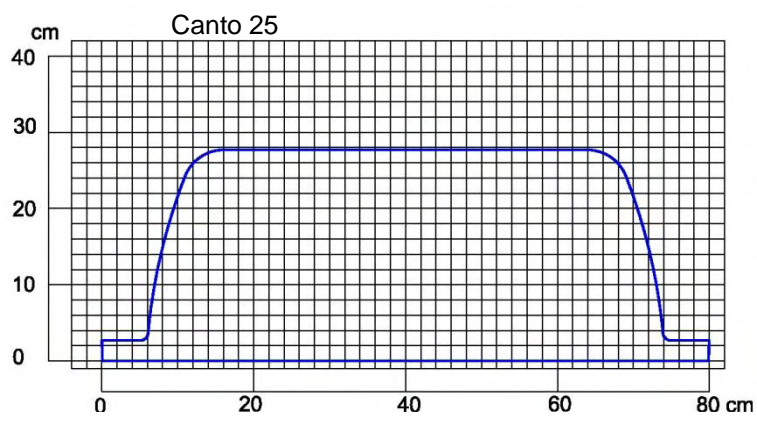

Geometrías Cubetas nervios 16 y 21

Canto 25

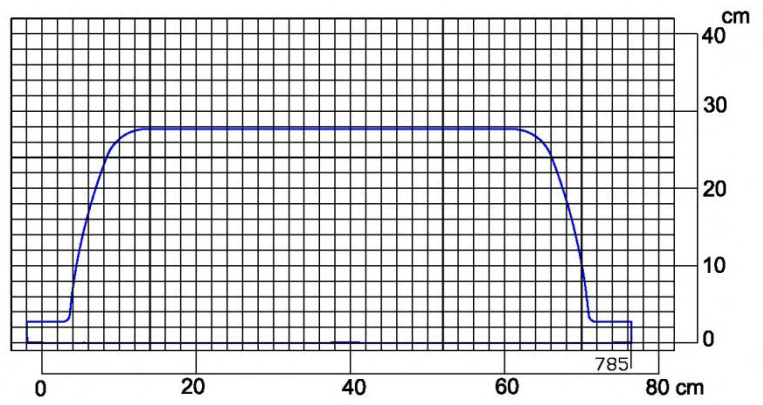
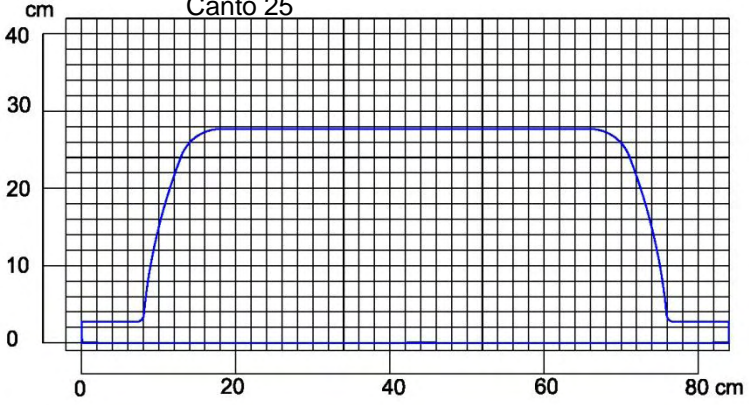

Canto 30

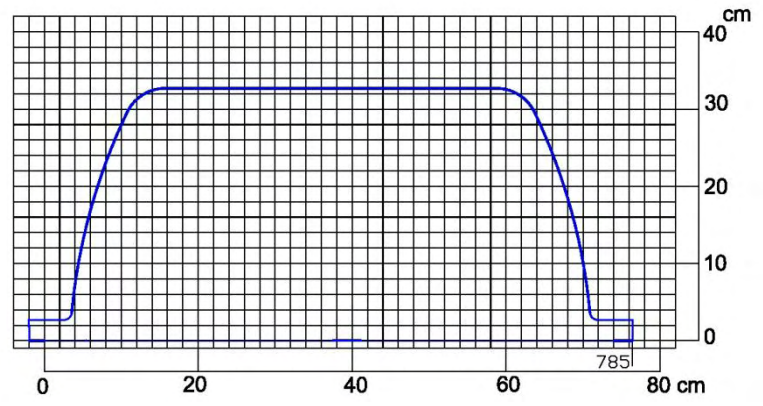
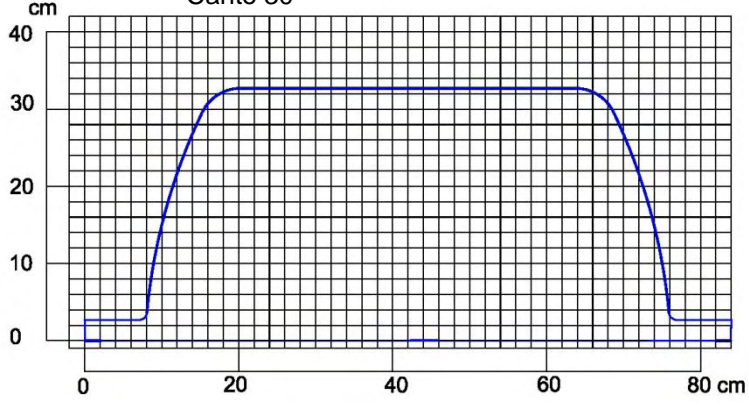



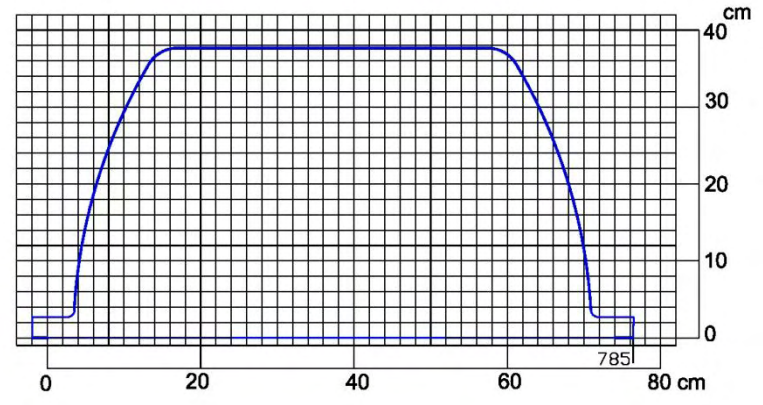
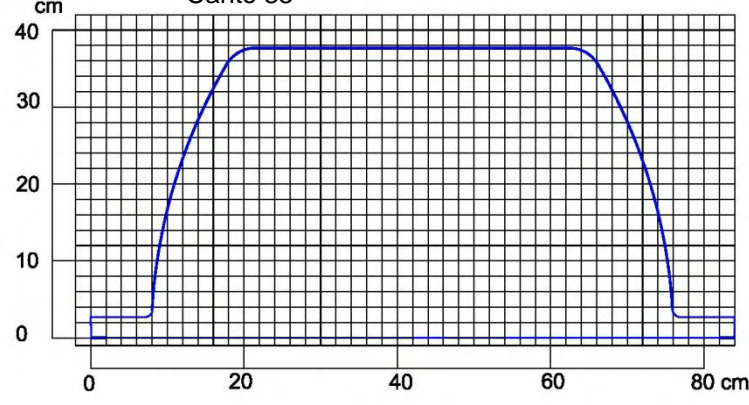

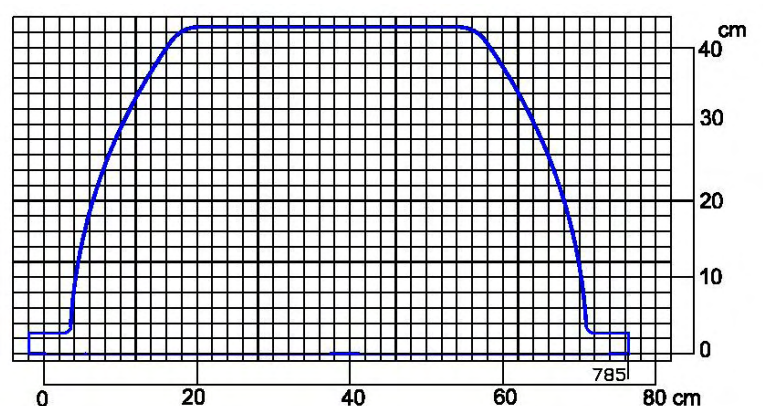
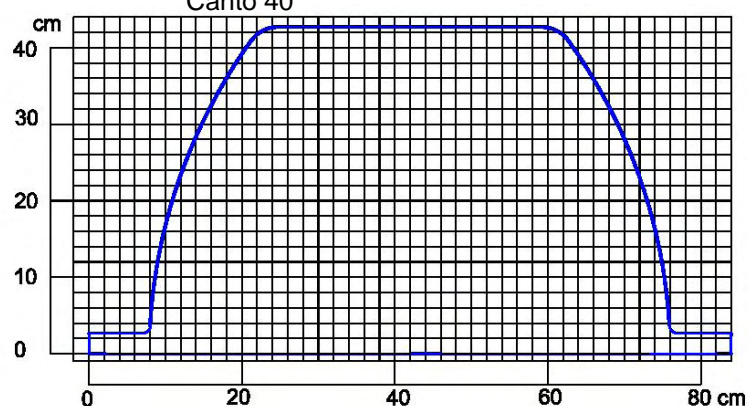

Canto 35



Canto 40

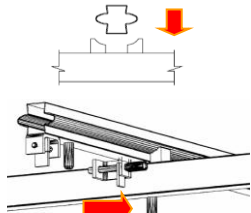

Utilización

<p>Unión entre portatasopandas:</p>		<p>Se inserta la hebilla y cerramos el pasador de seguridad, que impide la separación o levantamiento de los elementos.</p>	
<p>Unión entre guías:</p>		<p>Se inserta la hebilla y cerramos el pasador de seguridad, que impide la separación o levantamiento de los elementos.</p>	
<p>Unión entre guías y portata-sopandas:</p>		<p>Colocamos la portata-sopanda sobre la zona de asiento de las guías. Colocaremos las portata-sopandas de forma que al cerrar el pasador de la guía, este se introduzca dentro del tubo hueco de la portata-sopanda.</p>	

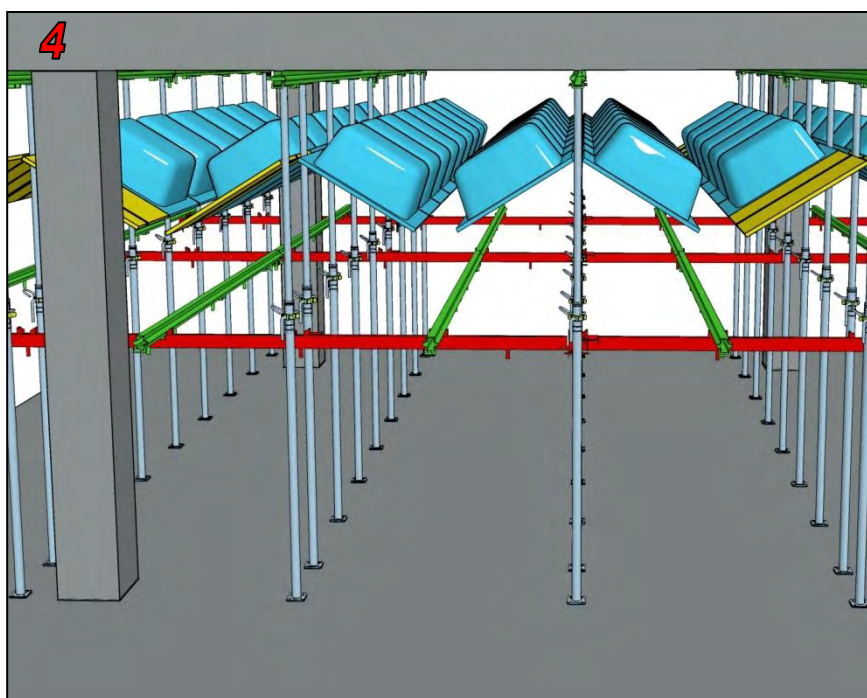
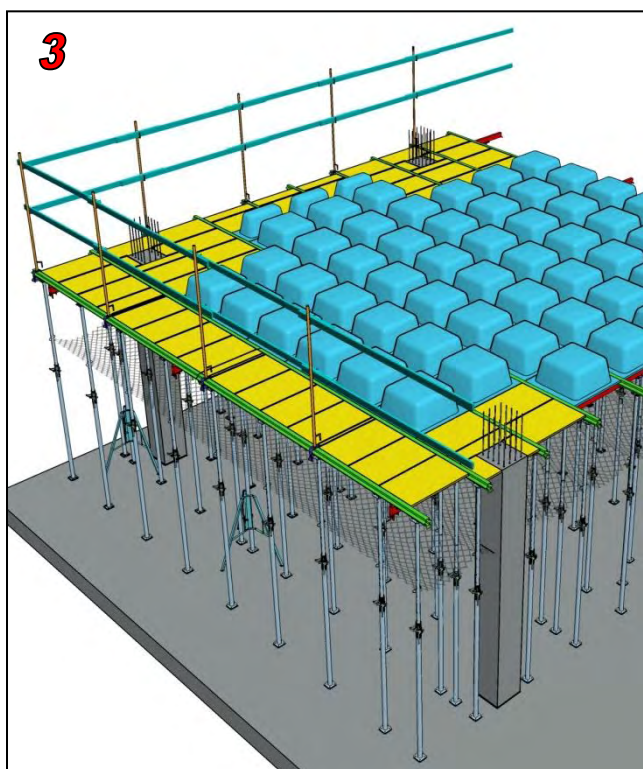
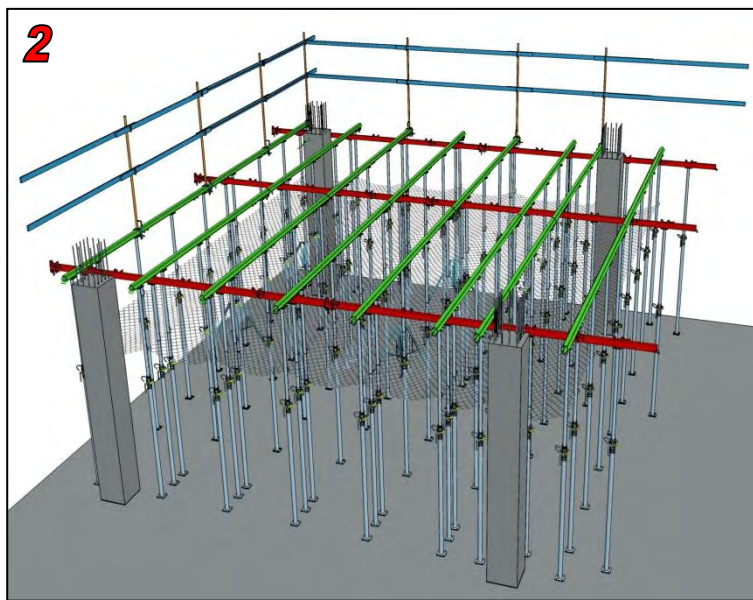
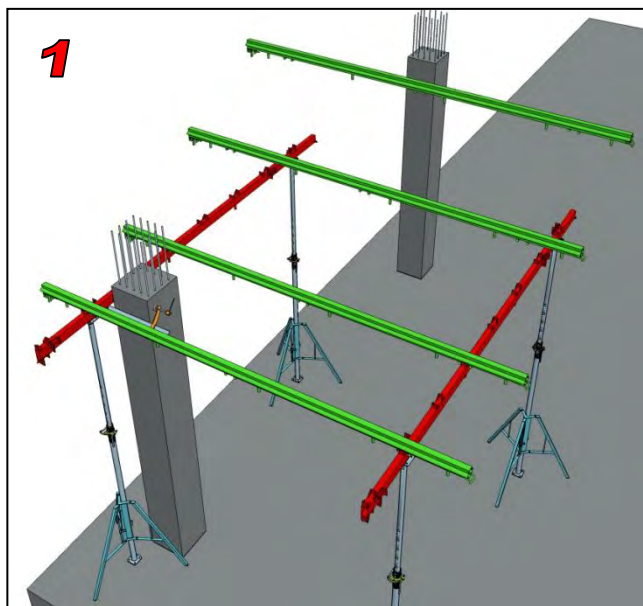

**Pautas de Control**

PAUTAS EN PORTATASOPANDAS	PROCEDIMIENTO SI NO CUMPLE
Que no tengan deformación longitudinal superior a 2cm, ni tengan abolladuras importantes, ni falten elementos	Rechazar
Que tengan los enganches y pestillos en buen estado	Rechazar
Sin manchas de óxido generalizadas	Rechazar

PAUTAS EN GUÍAS	PROCEDIMIENTO SI NO CUMPLE
Que no tengan deformación longitudinal superior a 2cm, ni tengan abolladuras importantes, ni falten elementos	Rechazar
Que tengan los enganches y pestillos en buen estado	Rechazar
Sin manchas de óxido generalizadas	Rechazar

PAUTAS EN CUBETAS	PROCEDIMIENTO SI NO CUMPLE
Comprobar la rectitud de las 4 alas de la cubeta	Rechazar
Que no haya fisuras que atraviesen, ni deformaciones o faltas de material importantes	Rechazar
Que las plantillas de metálicas se encuentren en buen estado y bien fijadas, sin deformaciones importantes	Rechazar

PAUTAS EN TABLEROS	PROCEDIMIENTO SI NO CUMPLE
Que no existan deformaciones importantes.	Rechazar
Que no haya fisuras o roturas transversales.	Rechazar
Sin tablas sueltas o descoladas.	Rechazar



Ilustraciones

